

Installation manual

HRC-EcoMax / HRC-MaxComfort

Balanced ventilation system with heat recovery

This manual is intended for installers of the HRC-EcoMax and HRC-MaxComfort balanced ventilation system. The manual contains important information about the installation and configuration of the ventilation unit with heat recovery. The user manual can be found on the right side of the unit.

This manual concerns the following models:

HRC-300 EcoMax

HRC-300-MaxComfort

HRC-300 EcoMax

HRC-400-MaxComfort

HRC-500-EcoMax

HRC-500-MaxComfort

Index

1. Precautions and safety instructions	3
2. Product information	4
3. Product overview	6
4. Installation	10
5. Installation components	19
6. Adjustment	25
7. Maintenance and Service	28
8. Technical specifications	39
9. Installation report	47
10. Product card	48
11. Warranty	50
12. EC declaration	50

1. Precautions and safety instructions

- Only a professional installer may install, connect, commission and carry out maintenance to the device unless otherwise specified in this document;
- The installation of the unit must be carried out in accordance with the general and locally applicable construction, safety and installation regulations of the municipality and electricity company;
- Make sure that the voltage is removed during work on the unit and cannot be switched on accidentally. Bear in mind that the motor will continue to run for approx. 20 seconds after switching off;
- The unit is only suitable for a 230V/50 Hz. connection;
- Modification of the unit or specifications stated in this document is not permitted;
- Touching the fans by hand must not be possible, therefore ventilation tubes of at least 900 mm length must be connected.

2. Product information

2.1 General product description

The HRC is a balanced ventilation system with heat recovery. This means that an equal amount of fresh filtered outside air is supplied to the living room and bedrooms while polluted air is extracted from the kitchen, bathroom and toilet. The heat of the extract air from inside is then transferred to the fresh filtered outside air. This results in significant energy savings.

The Orcon HRC is equipped with an intelligent electronic control circuit that ensures optimum operation and protection under all circumstances. The unit can be used as a left or right model. The unit is supplied as standard as a left model with a grounded plug and can be converted to a perilex model with a perilex power cord (article number: 22915405). For all models it is possible to use a radio remote control 15RF, CO₂ Roomsensor 15RF or a CO₂ Controlsensor 15RF; these are available separately.

2.2 Unit types

The different models are listed in the table below. Each model is suitable for both left and right mounting.

	HRC-300- EcoMax	HRC-300- MaxComfort	HRC-400- EcoMax	HRC-400- MaxComfort	HRC-500- EcoMax	HRC-500- MaxComfort
Item no.	22000080	22000085	22000090	22000095	22000100	22000105
Air flow rate [m³/h] at max. 200 Pa	300	300	400	400	500	500
Tube connection [mm]	ø150	ø150	ø180	ø180	ø180	ø180
Preheater	no	yes	no	yes	no	yes
Filter class (ISO16890)	2x coarse 65%	supply: ePM1 70% extract: coarse 65%	2x coarse 65%	supply: ePM1 70% extract: coarse 65%	2x coarse 65%	supply: ePM1 70% extract: coarse 65%

2.3 Scope of delivery

Before installing the HRC, check that it has been delivered complete and undamaged. It is complete if the following parts are included:

- HRC-EcoMax or HRC-MaxComfort with 230V earthed power cord
- Wall bracket
- Mounting set with 2x M8 bolts, 2x M8 washers and 2x plugs
- Installation manual
- User manual
- Connector piece 32mm / G1¼" for condensation drain
- 2x Orcon Filter (already in unit) (depending on unit model, see Chapter 2.2)
- Optional preheater (depending on unit model, see Chapter 2.2)

2.4 Optional accessories

Item	Article number
HRC chassis	22700080
Preheater	29190550
EFF ø125 Extractor valve	23121002
EFF ø160 Extractor valve	23121003
TFF ø125 Supply valve	23121012
TFF ø160 Supply valve	23121013
Dry condensation drain set	22700065
Filter set HRC 2x coarse 65%	22700002
Filter set HRC coarse 65% & ePM1 70%	22700006
Perilex power cord	22915405
CV-3 Perilex socket - surface mounted	28000005
CV-3 Perilex power socket - built-in	28000000
Remote control 15RF	21800000
CO₂ Roomsensor 15RF	21800040
CO₂ Controlsensor 15RF	21800045

2.5 Scope of application

The unit is only suitable for residential buildings and not for industrial use, swimming pools or saunas. The air flow rate from the unit must match the ventilation requirements of the home.

3. Product overview

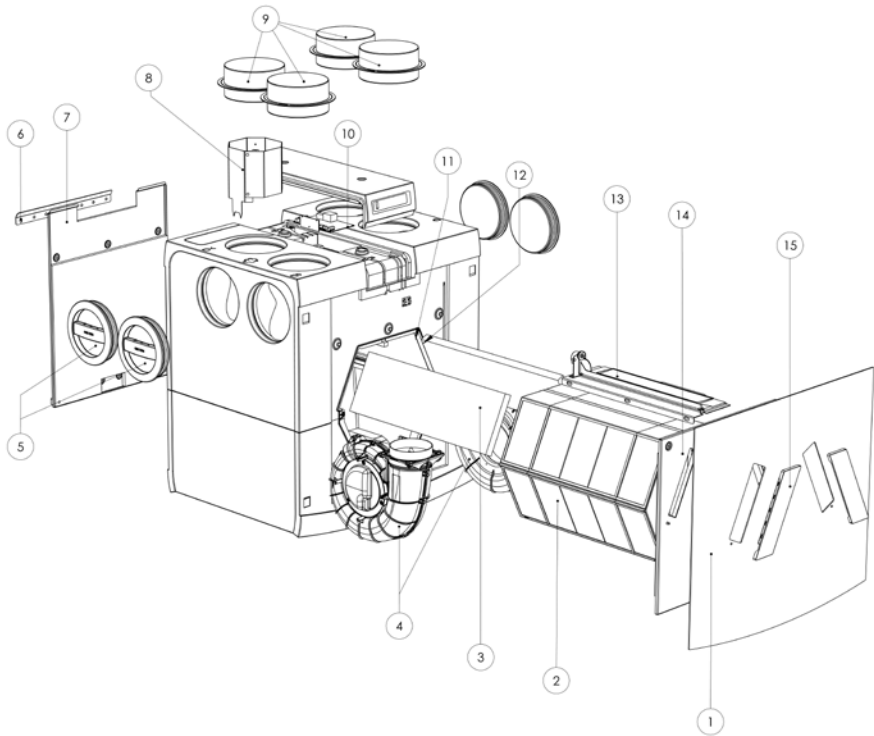

3.1 Parts

- | | | | |
|-----|--|-----|--|
| 1. | Front cover | 9b. | Connector flange 180mm (4x)
(HRC-400-EcoMax/MaxComfort) |
| 2. | Heat heater | 9c. | Connector flange 180mm (6x)
(HRC-500-EcoMax/MaxComfort) |
| 3. | Filter (2x) | 10. | Main circuit board, RF antenna |
| 4. | Ventilator module (2x) | 11. | Temperature sensor (2x) |
| 5. | EPP cap (4x) | 12. | Humidity sensor |
| 6. | Wall bracket | 13. | Bypass module |
| 7. | Metal back frame | 14. | Metal front frame |
| 8. | Preheater
(only with HRC-MaxComfort) | 15. | Filter cover left & right |
| 9a. | Connector flange 150mm (4x)
(HRC-300-EcoMax/MaxComfort) | | |

3.2 Operation

Bypass

In the summer, or when heat recovery is not desirable, the air is not passed through, but past the heat exchanger thanks to a bypass module. This makes it possible to ventilate the home with fresh outside air in the summer situation, during the night, so that the home is relatively cool again in the morning. The bypass opens when the inside temperature exceeds the set comfort temperature of 23°C and the outside temperature exceeds 15°C.

Frost protection

When the outside temperature in winter is around freezing, it is possible for ice to form in the exchanger. Cold air is blown into your house as a result. To prevent this, the HRC will heat the exchanger in time using the warm indoor air from your home. The unit will temporarily create an imbalance to achieve this.

For the MaxComfort models, the built-in preheater switches on and warms up the cold incoming outside air.

Constant volume

The unit is equipped with a constant volume control. This ensures that deviations in the air flow rates between the supply and extract air, for example due to weather conditions or when the filters become contaminated, are corrected automatically. In this way the unit remains constantly balanced and you are assured of sufficient air with maximum efficiency.

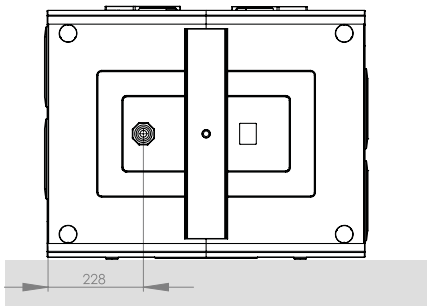
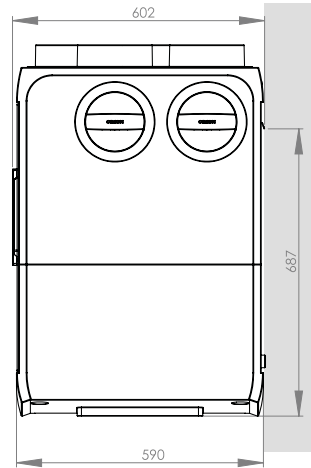
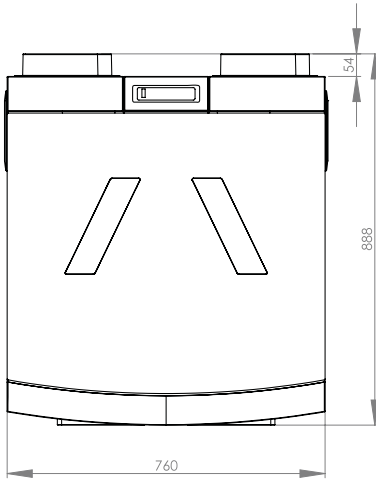
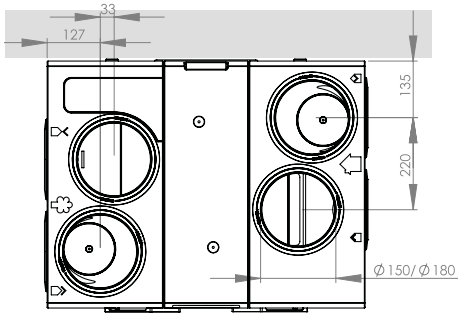

3.3 Dimensional drawing

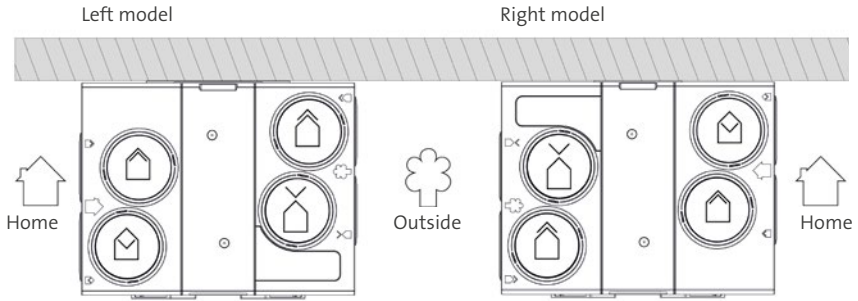

3.4 Duct indicator

When connecting the ducts it is important to take into consideration which model is being used - left or right mounting. The connections are indicated on the top of the unit with icons. The unit is supplied as a left model as standard. You can change your apparatus into a right mounted model (see Section 4.3).



Air ducts on the home side		Air ducts on the outside	
	Supply air from the unit to the home		Supply air from outside to the unit
	Return air from the home to the unit		Extractor air from the unit to the outside

4. Installation

4.1 Brief installation instructions

Step-by-step assembly:

1. Mount the wall bracket level on a wall with sufficient mass (200 kg/m²) with the supplied bolts and plugs, or mount the unit on the optional base in the case of floor mounting
2. Mount the Orcon extractor and supply valves in the various rooms
3. Configure the unit in the desired direction (see Chapter 4.3)
4. If desired, replace the earthed power cord with a perilex power cord
5. Set the required flow rate with the help of the DIP switches on the main circuit board (see Chapter 6)
6. Hang the unit on the wall bracket, or position the unit with the base in the desired location
7. Adjust the levelling feet so that the unit is hanging (wall mounting) or standing (floor mounting) level
8. Install 2 silencers of at least 1 metre (ducts to and from interior spaces)
9. Mount the ventilation ducts and conduits with as little air resistance as possible and free from leaks. Make sure no residual material from the pipes is able to reach the device.
10. Mount the condensation extractor (preferably dry siphon) under the unit
11. Mount the desired remote controls, CV-3 switch (for perilex) and/or CO₂ sensors (see Chapter 5)
12. Switch on the voltage of the HRC-EcoMax or HRC-MaxComfort unit
13. Report separately supplied remote controls and/or CO₂ sensors on (see Chapter 5), the supplied remote control is already registered to the unit as standard

4.2 Installation instructions

The HRC must be installed in compliance with:

- Quality requirements for residential ventilation systems, ISSO 61 quality requirements for balanced ventilation in homes, ISSO 62
- The capacity calculation in compliance with the Netherlands Building Decree
- Requirements for ventilation of buildings - determination methods for new buildings NEN 1087:2018
- The safety provisions for low-voltage installations, NEN 1010
- The requirements for connection to indoor drainage - design and implementation guidelines, NTR 3216:2012. Any additional requirements from the local energy companies
- The installation instructions for the HRC-EcoMax and/or HRC-MaxComfort

4.3 Changing the unit direction

The HRC is available in a left or right model. The HRC is by default supplied as a left model. The ducts are therefore connected to the home on the left side of the unit, and the ducts on the right side of the unit go outside. If you wish to use the HRC as a right model, it can be configured as follows:

1. Remove the plug from the socket
2. Place the device on a flat surface if the device is already suspended
3. Remove both filter covers
4. Remove the plastic front plate
5. Remove the metal front plate of the device by removing the 5 screws (wrench size T25)
6. Take the power cord out of the cable clamp on the metal back plate
7. Remove the metal back plate of the device by removing the 5 screws.
8. Move the metal front plate to the other side of the device and fasten the 5 screws
9. Move the metal back plate to the back of the device and fasten the 5 screws
10. Remove the circuit board cover on the top. Keep an eye on the length of the display cable when removing the circuit board cover. If necessary, temporarily separate it from the connector on the circuit board
11. Move the earthing cable to the new back of the device. Move the strain relief towards the recesses at the other wide of the circuit board as well
12. Reinstall the top cover such that the display is located at the front and fasten the 2 screws.
13. Return the earthing cable to the cable clamp on the metal back plate
14. Place the plastic front plate back to cover the metal front plate. Secure the front plate by pressing on the four outer corners
15. Reinstall the filter covers.

The device is now suitable for installation in a right-handed setup.

4.4 Electric connectors

The HRC is equipped with a earthed power cord as standard. Optionally, you can replace the earthed power cord with a perilex cord (article number: 22915405).

The place where the wall socket needs to be fitted is indicated in the figure below. The electrical installation must comply with NEN1010 and the requirements of the local energy company.

- Only place the plug in the wall socket when the entire installation is ready and no building material is present
- The unit is not suitable for 3-phase current
- Supply voltage: 230 Volt ~50 Hz

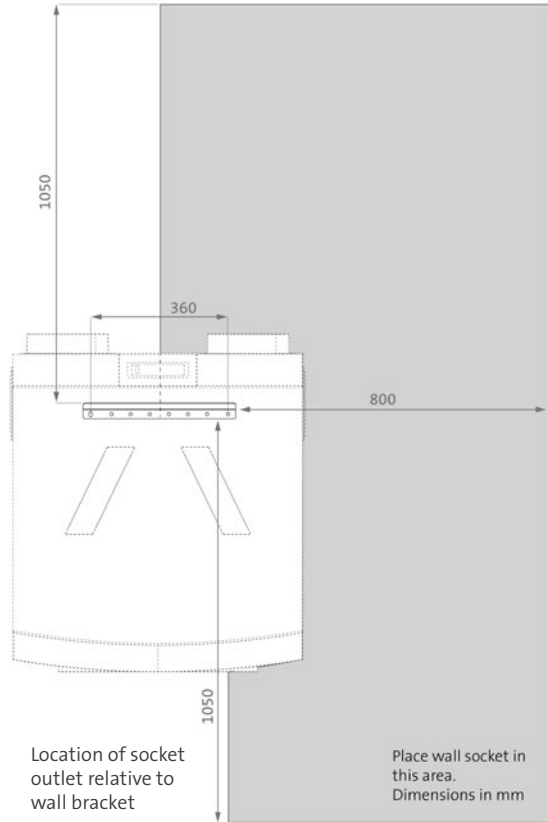

Fitting the HRC with a perilex cord



Caution: ensure that the unit is always disconnected from the power supply when changing the earthed power cord.

If you want to replace the earthed power cord with a perilex power cord, follow these steps:

1. Place the unit on a flat surface.
2. Remove the earthed power cord from the cable clamp on the metal rear frame
3. Remove the printed circuit board cover on the top of the unit by unscrewing the 2 screws using a Torx screwdriver (key size T25)
4. Remove the connector from connection X27
5. Remove the earthed power cord from the cable recess.
6. Using a flat screwdriver, attach the black wire of the perilex cord to position 2 (centre) of screw connector X9.
7. Using a flat screwdriver, attach the black wire of the perilex cord to position 3 (under) of screw connector X9.

8. Place the white connector of the perilex cord on connection X27.
9. Feed the perilex cord through the cable recess. Place the strain relief in the appropriate recess.
10. Screw the strain relief hand tight using a Torx screwdriver (key size T20)
11. Replace the top cover and re-tighten the 2 screws
12. Reinsert the earthed perilex cord into the cable clamp on the metal back frame
13. Place the plug in a perilex wall socket which is connected as shown in the diagram below.

Speed control for perilex connection

A 230 Volt power supply (terminals L3 and N) must be connected to the perilex wall socket. The speed is controlled by means of a 3-position switch, which receives power (L3) from the perilex socket (wire diameter 1.5 mm²). A black (L2) and grey (L1) wire leads from the switch back to the perilex wall socket. It is important that terminal L3 is always supplied with voltage. For the correct way to connect the cabling, see the wiring diagram below. Optionally, an RF Remote Control, CO₂ Controlsensor or a CO₂ Roomsensor can be combined with the CV-3 switch. If several switches or controls are used in the home, the last selected ventilation position always takes precedence.

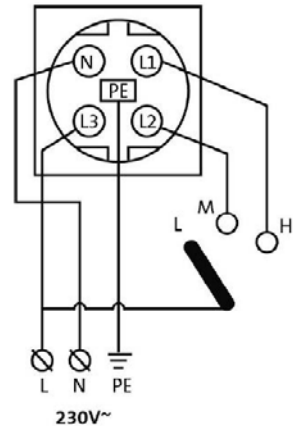

Explanation of 3 ventilation settings

Setting 1	Low	Absent setting	For use during absence during a long period
Setting 2	Medium	Present setting	For daily use with normal use within the home
Position 3	High	High setting	For use during cooking, showering or parties

Connections to printed circuit board

No.	Function	Pin function
X1	RF antenna connection	
X9	Perilex input	L – 230V 2 – L2 (black, 230V) Medium setting 3 – L1 (grey, 230V) High setting
X10	Modbus Communication duct to ventilators	1- RSA (2x White) 2- RSB (2x Brown) 3- GND (2x green)
X13	Supply ventilator power supply	1 – L2 – PE3 – N
X14	Extractor ventilator power supply	1 – L2 – PE3 – N
X15	Bypass stepper motor control	
X18	Humidity sensor input	
X22	Temperature sensor 1 input (return air from inside)	1 – Earth 2 – Sensor
X23	Temperature sensor 2 input (supply air from outside)	1 – Earth 2 – Sensor
X27	230V mains	1 – L(3)2 – PE3 – N
X33*	Display connection	Flat cable
X34*	DIP switches extractor	8 dip switches
X35*	DIP switches supply	8 dip switches

*on top board

4.5 Installing the unit

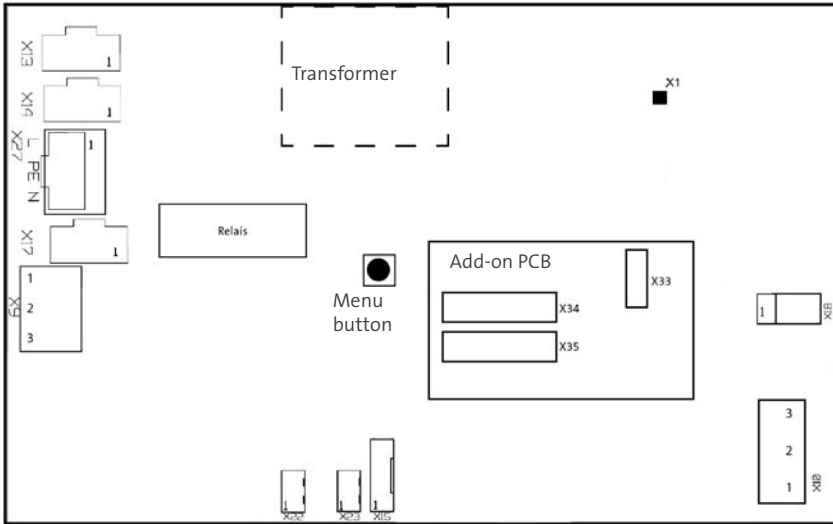

Wall mounting

The unit can be hung on the supplied wall bracket. But only if the wall has a minimum mass of 200 kg/m^2 is available.

1. Attach the wall bracket to the wall using the bolts and plugs supplied. **Caution:** mount the wall bracket using a spirit level before you connect the ducts! Sufficient space must be left underneath the wall bracket for the condensation extractor (see chapter 4.7).
2. Place the HRC in the left or right configuration over the wall bracket, by hooking the hook on the back of the unit over the wall bracket.
3. Turn the levelling feet on the back of the unit so that it hangs level against the wall. This ensures that the condensation extractor works optimally.

Floor mounting

If there is no wall that is suitable for wall mounting, the HRC can also be placed on a concrete floor using the optional Orcon base (article number: 22700080) for floor mounting.

1. Place the legs in the recesses on the bottom of the unit (Figure A). This works best when the unit is on its side.
2. If necessary, use a spirit level to adjust the levelling feet so that the unit is level on the floor (Figure B).

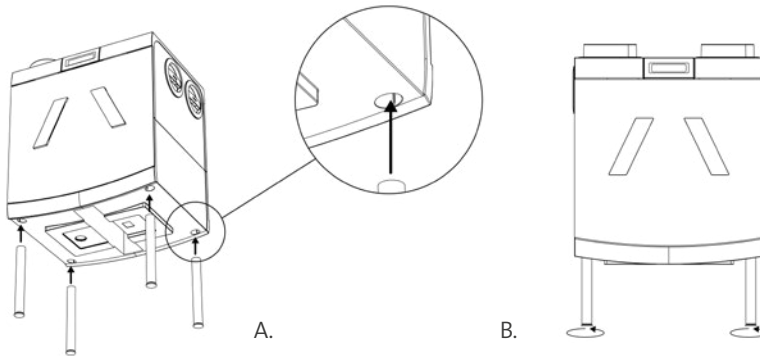

4.6 Connecting ducts to the unit

Once the unit is fitted, the ducts can be mounted. The ducts (return) from and to the home (supply) are on one side of the unit, and the ducts from and to the outside are on the other side. In order to prevent condensation on the ducts from and to the outside, these must always be insulated externally to ensure that they are damp-proof. It is preferable to use preinsulated plastic ducts made of PE or PUR. Try to keep these ducts as short as possible.

It is advisable to connect the ducts to and from the home to the unit using sound dampers with a minimum length of 100 cm. When measuring the ducts, bear in mind that not too much energy is lost when transporting the air through ducts that are too narrow. It is preferable not to have the total resistance of both the supply system and the discharge system exceed 100 Pascals. The supply duct system must be fitted in such a way that NEN 1070, table 4 is complied with in the nominal setting. Think of crosstalk and installation noise, also with underfloor ducts. Ensure that the supply ducts are insulated if necessary, e.g. if they are installed outside the insulated skin.



Attention: make sure no residual material is able to reach the device while installing the pipes to prevent it from damaging the device.

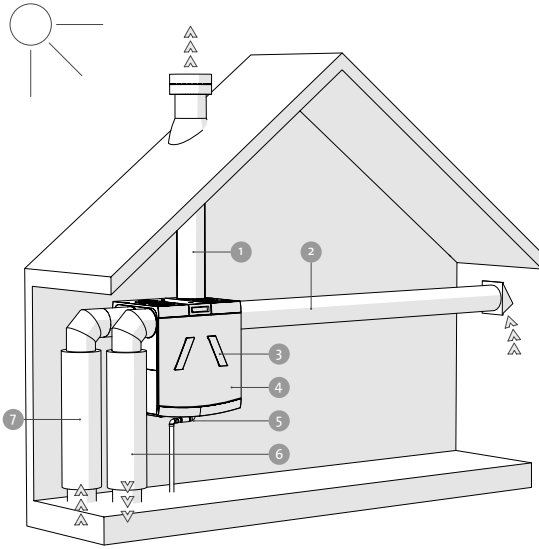

1. Air outlet
2. Air supply
3. Unit fitted with correct filters
4. HRC (install using spirit level)
5. Connect condensation drain according to installation instructions
6. Connect the supply duct using acoustic insulation
7. Connect the extractor duct using acoustic insulation

Feed exhaust and supply duct through the roof boarding in such a way that no condensation water is created in the roof boarding and everything is airtight; also install the exhaust duct between the HRC and the roof outlet so that surface condensation is prevented. Select the extractor location for the mechanical ventilation air and sewer ventilation so that no hindrance occurs with regard to the supply.

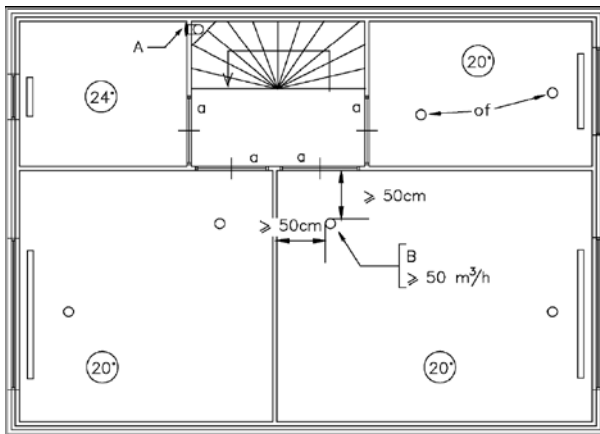

Select the location of the supply valves so that pollution and draft are prevented.

A Extractor valve $\varnothing 125$ plastic (MKL) or metal (EFF-125/ EFF-150/160)

B Supply valve $\varnothing 125$ (TFF-125) or $\varnothing 160$ (TFF-160)

a 2 cm slit under the door. Install sufficient overflow openings.

4.7 Condensation extractor

The HRC must always be fitted with a condensation extractor underneath the unit. It is preferable to use a dry siphon (article number: 22700065), which can be ordered separately. Because this requires less space underneath the unit, there is less chance of air leaks and it does not dry out on hot days, which prevents odour issues. When connecting the siphon, always use PTFE tape to prevent leaks.

Standard siphon

The unit is supplied with a standard 32 mm connector with threaded end. This can be connected to the bottom of the unit on internal thread (G1 ¼"). The condensation water must be extracted through the inner sewer system free of frost and on a slight incline. A water trap of at least 80 mm must be installed to prevent an air leak and sewer odour from spreading into the ventilation system. A siphon with a diameter of 40 mm must be placed under the water trap. Preferably use a threaded connector and rubber gasket for easy cleaning of the siphon. When connecting the siphon, always use PTFE tape to prevent leaks.

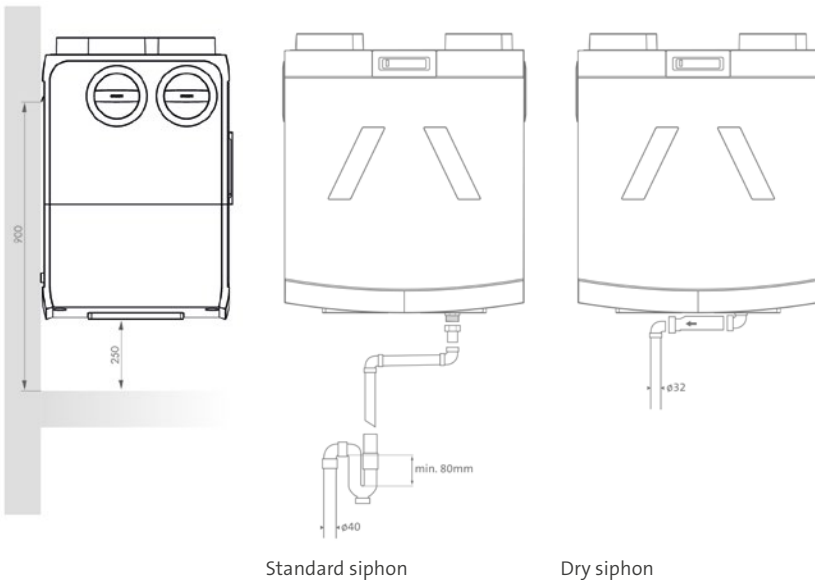

5. Installation components

5.1 Remote control 15RF (optional)

Mounting

The remote control can be opened using the push button at the bottom (image below). The wall frame can then be mounted with the 2 screws and plugs supplied or glued. **Caution:** the "UP" mark on the wall frame must always be at the top. Keep enough space at the bottom so that the push button can be easily reached from below. It is recommended to place the remote control in an easily accessible place in the living room, kitchen or toilet. Never place the remote control near large metal objects. Large metal objects can disrupt the radio-controlled signal.

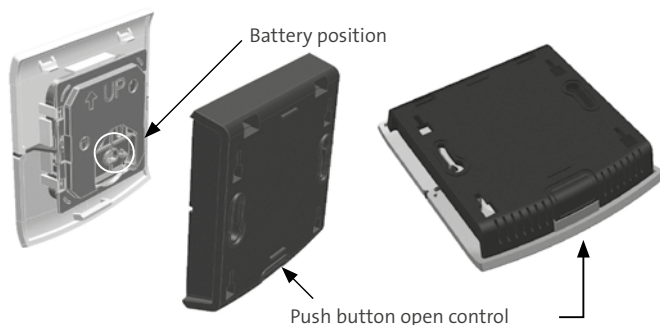

Registration

The remote control must be registered. In total, up to 20 RF components can be connected to the unit.

- *On 1 unit*
Unplug the unit from the wall outlet for 10 seconds. Then put the plug back in the socket. The unit will remain in set-up mode for 3 minutes and you can register the remote control. Press the keys <1> and <auto> simultaneously until the LED on the remote control flashes red, green and red alternately. The LED on the remote control will now flash green 10 times, the remote control is ready for use. Registering an extra remote control is done in the same way.
- *On multiple units*
To register 1 remote control on more than one unit, the above registration procedure is repeated, just press the key <2> and <auto> until the LED on the remote control flashes alternately red, green and red.

- Resetting remote control 15RF*

To replace a remote control, all components on the unit must be de-registered. All components must then be registered again. A remote control can be reset (and thus de-registered) by simultaneously pressing the <absent> and <timer> keys for 3 seconds. The remote control indicates that the reset is complete when it flashes orange twice.

Remote control

The remote control for the unit has 6 buttons. The functions of these buttons are explained in the table below.





- Absent setting*

In the absent position, the unit runs in an extra energy-efficient low setting and does not respond to demand from the sensors.
- Timer setting*

In the timer mode, the unit runs the desired time in the high position, after the time has elapsed, the unit returns to the last selected position. The timer can be cancelled by selecting another setting.
- Automatic mode*

In car mode, the unit runs based on the moisture content in the home or based on the optional CO₂ sensors. If there is no ventilation demand, the unit runs as standard in position 1. When there is a ventilation demand from the humidity sensor or the optional CO₂, the unit will modulate the ventilation to the medium setting (setting 2).

Explanation of remote control buttons

Button	Operation	Function
	1x short	Absent setting (same as low setting)
1	1x short	Setting 1 (low setting)
2	1x short	Setting 2 (medium setting)
3	1x short	Setting 1 (low setting)
	1x short	Setting 3 (timer mode) temporary 15 minutes
	2x short	Setting 3 (timer mode) temporary 30 minutes
	3x short	Setting 3 (timer mode) temporarily 60 minutes
auto	1x short	Automatic mode

5.2 CO₂ Roomsensor 15RF

Mounting

The CO₂ Roomsensor and CO₂ Controlsensor can be opened via the push button on the bottom. The remote control is supplied with 230V mains power. To connect the control to 230V, open the cover for the power supply. This can be opened using a flat head screwdriver. The wiring (max. 1.5 mm²) for the 230V supply voltage, it can then be fed into the wall frame and connected to the terminal block behind the cover.



The cover must be on at all times to protect the terminal block. The wall frame can then be mounted with the 2 screws and plugs (not supplied) to a flush-mounting box or wall. Caution: the push button on the wall frame must always be at the bottom. Keep enough space free at the bottom so that the push button can be easily reached from below. It is recommended to place the sensor near the thermostat or light switch at a height of 1.5 metres in the living room or kitchen. Any additional sensors must be placed in the other living spaces. Do not place the sensor near large metal objects and mount it out of the reach of children.

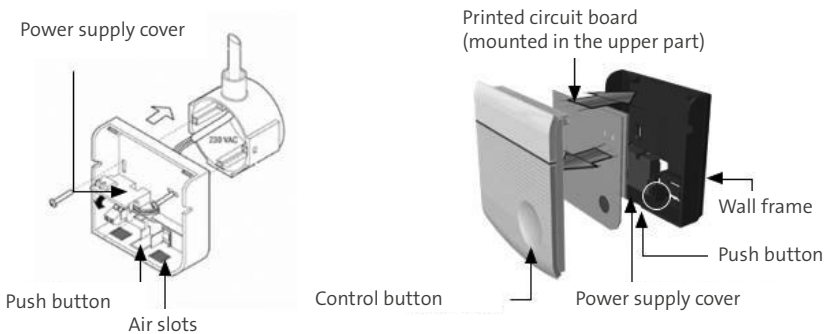

Register CO₂ Roomsensor 15RF

- On 1 unit*

Remove the plug from the HRC for 10 seconds. Then return the plug back to the socket. The unit will remain in set-up mode for 3 minutes. Restart the CO₂ sensor by removing it from the wall frame and then replacing it. Press the control button on the CO₂ sensor once briefly, then hold down for 4 seconds until one LED on the right lights up and the status LED flashes red and green alternately. The CO₂ Roomsensor is ready for use. Registering an extra CO₂ sensor is done the same way.
- Multiple units*

To register one CO₂ sensor on multiple units, the above procedure is repeated, but the control button must now be pressed for 8 seconds until the two LEDs light up.
- Reset CO₂ Roomsensor 15RF*

To replace a CO₂ sensor, all components on the unit must be de-registered. All components must then be registered again. A CO₂ sensor can be reset to factory settings by pressing the control button for 15 seconds until the red and green LED lights up simultaneously (orange). Now release the push button.

Operating the CO₂ Roomsensor 15RF

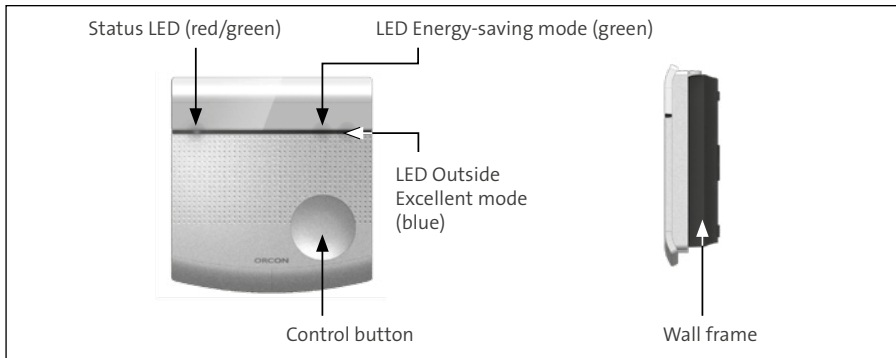

By tapping the control button once, the status is displayed by the LEDs. The LEDs will go out automatically after 30 seconds. If the remote control button is touched again after holding down once, the CO₂ Roomsensor will switch to another mode. Changing this mode can be recognised by the green or blue LED on the top right of the CO₂ Roomsensor lighting up.

There are 2 options:

- **Energy-saving mode (green)**
In this mode the unit will ventilate according to the standard requirement. This saves on energy costs; ventilation is only done when it is really needed.
- **Excellent mode (blue)**
In this mode, the CO₂ Roomsensor keeps the air quality level at a high level. As a result, more is ventilated so that the dirty air particles can be extracted from the home faster and clean outside air is brought in.

5.3 CO₂ Controlsensor 15RF

Mounting

The CO₂ Controlsensor is mounted in the same way as the CO₂ Roomsensor.

Registration

- *On 1 unit*
Remove the HRC plug from the socket for 10 seconds. Then return the plug back to the socket. The unit will remain in set-up mode for 3 minutes. Restart the CO₂ sensor by removing it from the wall frame and then replacing it. Briefly press the control button once on the CO₂ Controlsensor; the red LED on the control will now flash. Then hold down for 3 seconds until one LED on the right lights up and the status LED flashes red and green alternately. Once the CO₂ Controlsensor has been successfully registered, the green LED will flash 10x.
The CO₂ Controlsensor is ready for use. To register an extra CO₂ Controlsensor repeat the above procedure.
- *On multiple units*
To register one CO₂ on multiple units, the above procedure is repeated, except that the control button must now be pressed for 8 seconds until 2 LEDs on the right-hand side of the CO₂ Controlsensor lights up.
- *Reset CO₂ Controlsensor*
A CO₂ Controlsensor can be reset to factory settings by pressing the control button for 17 seconds until the red and green LED light up simultaneously (orange). Now release the push button. The CO₂ Controlsensor restarts and has been reset.

Operation

By tapping the control button once, the status is displayed by the LEDs. The LEDs will go out again automatically after 30 seconds. This to make sure there is no distracting lights in dark bedrooms, or forms a distraction in other living areas. If the remote control button is touched again after holding down once, the CO₂ Controlsensor will switch to another setting or mode.

CO ₂ Controlsensor		
	Absent setting	Unit runs at the lowest possible setting
auto	Automatic setting	Automatic control based on moisture and CO ₂
1	Setting 1	Temporary low setting (60 min)
2	Setting 2	Temporary medium setting (13 h)
3	Setting 3	Temporary high setting (60 min)

- Absence and setting 1,2 and 3*

A minimum amount is ventilated in the absent setting. This setting remains active for 12 hours or until it is manually reset to automatic mode. Settings 1 (low), 2 (medium) and 3 (high) are temporary settings. If one of these settings is selected, the system will return to automatic mode after 60 minutes. During this setting the LEDs of the selected setting will remain lit.
- Automatic mode*

In automatic mode, the ventilator will ventilate based on the moisture and CO₂ content in the home. This saves on energy costs; ventilation is only carried out when it is really needed.

5.4 Resetting the HRC

If you have replaced a component, you must first reset the HRC before registering a new component. To do this, remove the printed circuit board cover on the top of the unit. Hold down the push button on the central printed circuit board in the unit **for 15 seconds** until the LED lights up orange. Release the push button. The link with the remote control/CO₂ sensors has now been deleted and the factory settings have been loaded. After this, the LED on the printed circuit board will remain in set-up for **3 minutes** and can be linked with components.

If you need support with the installation of the above components, you can always consult our instruction videos at: www.orcon.nl/service/onderhoud/

6. Adjustment

6.1 DIP switches

The DIP switches on the printed circuit board are used to adjust the air volume for each ventilator. The upper row of DIP switches controls the extractor ventilator and the lower row controls the supply ventilator. Because both ventilators can be set independently, it is possible to create a difference in the amount of air. This can be used when a negative or positive pressure is desired.

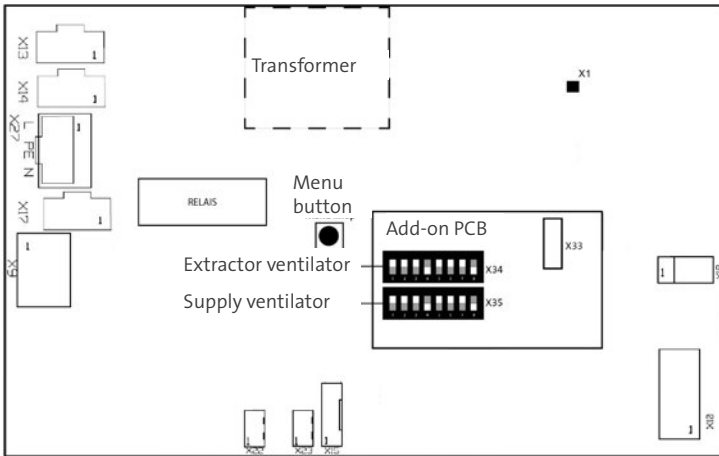

Procedure

1. Close the windows and doors
2. Open the extractor valves and supply valves to the maximum
3. Remove the plug of the balance ventilation unit from the wall socket
4. Unclip the filter covers and check whether the filters are clean. Clean or replace if necessary. Replace the filter covers
5. Unscrew the 2 screws on the top of the printed circuit board cover using a Torx screwdriver (T25). The printed circuit board cover can then be detached from the unit housing, the DIP switches on the printed circuit board are now accessible.

Caution: The display cable in the cover is attached to the print. Open the cover carefully to prevent cable breakage
6. Set the desired air volume for both ventilators with the DIP switches. See the table and image below
7. Restart the unit and adjust the unit to setting 2 or 3
8. Measure the total air volume on the Orcon extractor and supply valves and adjust the air volume for each ventilator if necessary
9. Set the valves to the correct flow rate per room
10. Completing the installation report (see Chapter 9)
11. Replace the printed circuit board cover and screw it down tightly

Adjusting the DIP switches

Setting		HRC 300	HRC 400	HRC 500	DIP switch number:							
		[m ³ /h]	[m ³ /h]	[m ³ /h]	1	2	3	4	5	6	7	8
Low	1	45	60	75	Off	Off
	2	80	90	100	On	Off
	3	115	120	125	Off	On
	4	150	15	150	On	On
Medium	5	150	150	150	.	.	Off	Off	Off	Off	.	.
	6	165	165	170	.	.	On	Off	Off	Off	.	.
	7	175	180	195	.	.	Off	On	Off	Off	.	.
	8	185	200	220	.	.	On	On	Off	Off	.	.
	9	195	215	240	.	.	Off	Off	On	Off	.	.
	10	200	230	265	.	.	On	Off	On	Off	.	.
	11	210	250	290	.	.	Off	On	On	Off	.	.
	12	225	265	310	.	.	On	On	On	Off	.	.
	13	230	280	335	.	.	Off	Off	Off	On	.	.
	14	240	300	360	.	.	On	Off	Off	On	.	.
	15	250	315	380	.	.	Off	On	Off	On	.	.
	16	260	330	400	.	.	On	On	Off	On	.	.
	17	270	350	430	.	.	Off	Off	On	On	.	.
	18	280	365	450	.	.	On	Off	On	On	.	.
	19	290	380	475	.	.	Off	On	On	On	.	.
	20	300	400	500	.	.	On	On	On	On	.	.
High	21	210	280	350	Off	Off
	22	240	320	400	On	Off
	23	270	360	450	Off	On
	24	300	400	500	On	On

6.2 Valves

You should preferably use TFF supply valves or EFF extractor valves. When installing the valves, consider the following:

- Make sure the supply and extractor valves are **at least 1.5 m** away from each other so that the airflows cannot come into contact with each other
- It is preferable not to place the valve close to a wall to prevent contamination
- To limit the resistance, we recommend that you use only valves equal to or larger than size $\varnothing 125$ mm
- Maximum extractor flow rate per valve: $75 \text{ m}^3/\text{h}$
- Maximum supply flow rate per valve: $50 \text{ m}^3/\text{h}$

Choose air ducts

When choosing the right ducts, the flow rate and maximum air speed are decisive in order not to generate additional noise pollution and a pressure drop (see table). Ensure that the total pressure loss is as low as possible (target ≤ 100 Pa) and the air speed in each duct is **lower than 3 m/s**.

Select air ducts	
Desired flow rate (m^3/h)	Recommended minimum duct diameter (mm)
0 - 30	>100
30 - 150	>125
150 - 350	>150
350 - 450	>180
400 - 500	2x 180mm (use side and top connection)

6.3 Constant volume control

Due to the built-in anemometer in the ventilator housing, the set air volume is always achieved to an accuracy of 1%. As a result, you are always assured that the set air volume is at the maximum efficiency, despite obstructions in the airflow caused by things such as contaminated filters or channels.

7. Maintenance and Service

7.1 Maintenance

The following components of the Orcon ventilation system must be cleaned regularly:

- Filters (cleaned every 3 months and replaced every 6 months, see user manual);
- Humidity sensor (at least every 3 years);
- Remote control and CO₂ sensors (see user manual);
- Valves and grilles (at least every 2 years);
- Ventilators (at least every 3 years);
- Heat exchanger (at least every 5 years);
- Housing (at least every 5 years);
- Ducts (at least every 5 years).

Preparation



The maintenance must be done with the HRC power switched off.

For most major maintenance, the unit can remain on the wall during wall mounting. After switching off the mains voltage, the filter handles and the plastic front grille can be clicked loose, the filters can be removed and the metal front frame can be unscrewed. After removing the heat exchanger, all the other internal components can be reached. After maintenance, the metal front frame can be screwed on again. Replace the filters afterwards. The plastic grille and filter handles can then be clicked on respectively. The plug can then be plugged in again.

Cleaning the humidity sensor

- The humidity sensor is located in the extractor duct from the home. You can reach this via the side connector or the top connector.

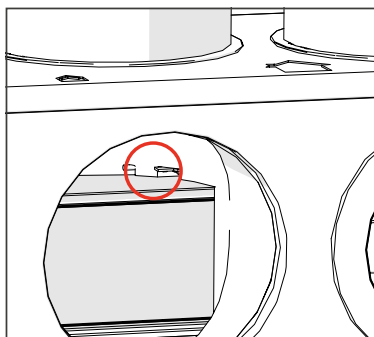
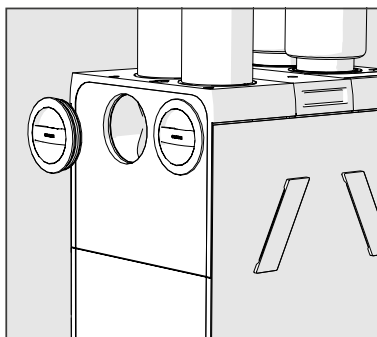

- The humidity sensor can remain in place or easily be removed from the connector. It can then be cleaned carefully using a dry brush.
- If the humidity sensor has been removed for cleaning, replace it in the connector after cleaning.

Caution: if the black dot on the sensor is facing you, the red wire should be positioned on the left side of the connector (see the image opposite). Then place the humidity sensor with the black dot downwards in the designated recess in the housing as shown in the adjacent image.

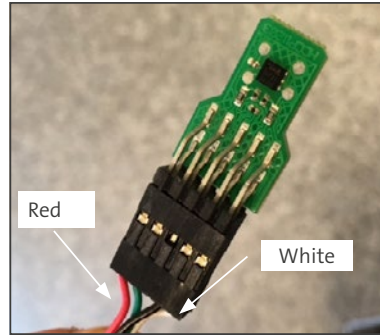

- If the bypass module has been removed to reach the moisture sensor, replace it as shown in the image below. **Caution:** pull the bypass cable up at the same time. Check whether the frame is stuck in the housing at the points indicated in the image below (green).

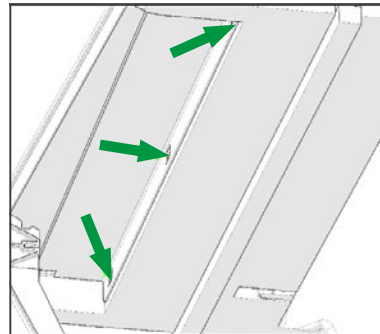
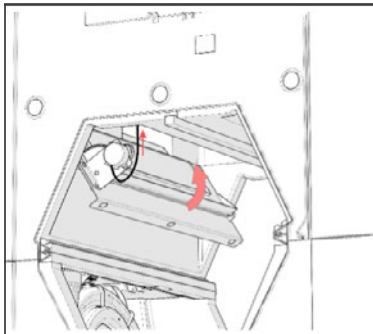
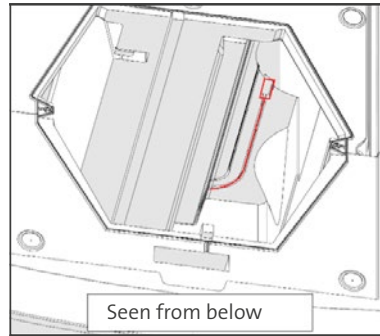

Cleaning the heat exchanger

The heat exchanger can easily be taken out of the unit with the help of the draw band. The heat exchanger must be cleaned with lukewarm water (max. 40°C). Allow most of the water to drain out and dry the heat exchanger as far as possible before replacing it in the unit.

Caution: The exchanger must be replaced facing the same way as when it was taken out of the unit. You can check this by aligning the sticker on the exchanger with the sticker of the same colour on the EPP housing.

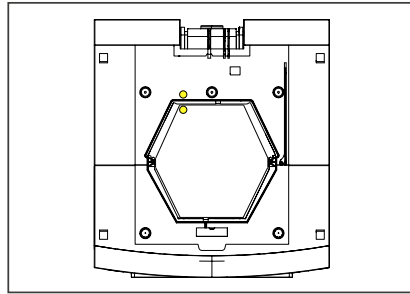
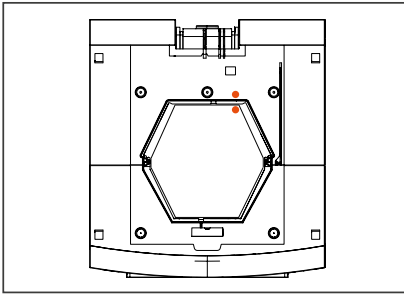
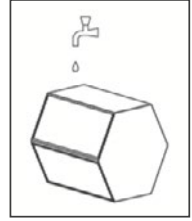

Caution: when replacing, the heat exchanger fins should slide through the slots in the EPP housing to prevent leakage between airflows and damage to the housing.

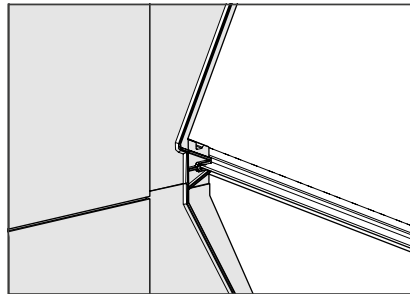
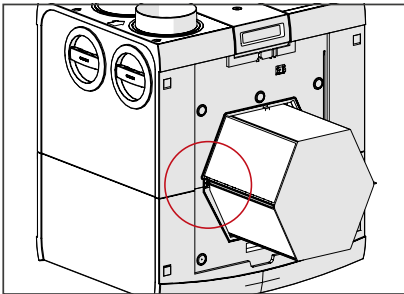

Cleaning ventilators

The ventilators must be cleaned if they are dirty. The ventilators can be easily reached when the heat exchanger has been removed from the unit.

First push down the ventilator module slightly. The module can then be taken out of the unit by turning it anti-clockwise and at the same time shifting it slightly so that the rib on the fan housing no longer clamps into the EPP. If the screw point on top of the fan housing is flush with the recess in the unit housing, the fan can be tilted. Then disconnect both connectors from the ventilator module. This can now be taken out of the unit.

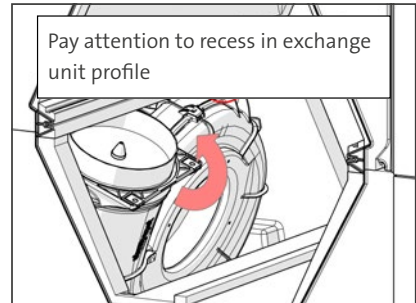

Then clean the fan with compressed air or a brush: do not use water. Ensure that all dirt is removed from the impeller. Do this for both ventilators.

Caution: the small ventilator at the top of the housing and the ventilator blades must not be damaged; this creates an imbalance and unnecessary extra noise. This also shortens the lifespan of the fans. After cleaning, make sure that the impeller at the top of the ventilator module is properly tightened by pressing on top of the cone shape.

Then place the fan back in the unit. First reconnect the connectors to the ventilator module. The fan can then be replaced in the unit in the same way as it was removed. This is made easier by aligning the screw point on top of the fan housing with the recess in the unit.

Caution: The ventilator module is correctly in place when the rib on the fan housing is clamped back in the slot in the EPP and the flange on top of the housing falls into the EPP.

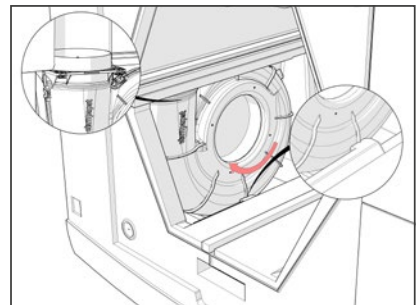

Caution: After replacing the ventilators, they need to be reallocated. The correct allocation is very important for the correct operation of the balance ventilation unit!

1. Disconnect the power supply to both fans on the printed circuit board and unplug the earthed plug from the socket
2. Put the earthed plug back in the socket, wait 10 seconds and pull it out again
3. Connect the supply ventilator power supply to the printed circuit board (connector X13)
4. Put the earthing plug back in the socket, the address of the supply ventilator is now assigned.
5. Disconnect the earthed plug from the socket after 10 seconds
6. Connect the extractor ventilator power supply to the printed circuit board (connector X13)
7. Put the earthed plug back in the socket; the address of the extractor ventilator is now also assigned

7.2 Indication messages

I. Remote control 15RF

When a button on the remote control is pressed, the LED lights up green, then it will flash to confirm. The following errors are possible:

Overview indications remote control RF15	
Indication	Remote control message
Unit OK, message followed up	1x green
Unit OK, timer activated for 15 minutes	1x green
Unit OK, timer activated for 30 minutes	2x green
Unit OK, timer activated for 60 minutes	3x green
RF Communication problem	3x red
Configuration mode starting up	1x red 1x green 1x red
Successful connection with unit	10x green
Battery almost empty	1x orange 2x green
Reset remote control carried out	2x orange
Filter indication active	3x orange

II. CO₂ Roomsensor 15RF

When the LED on the CO₂ is permanently green, the CO₂ Roomsensor is functioning correctly and there is a connection to the ventilation unit. Roomsensor correct and there is connection to the ventilation unit.

If the status LED flashes red 3 times, there is no radio-controlled communication with the ventilation unit. Check whether the ventilation unit is connected to the power supply. Register the CO₂ Roomsensor on the ventilation unit according to the instructions. If a malfunction occurs in the CO₂ Roomsensor, then the status LED will 1x flash red repeatedly. Please contact the Orcon service department.

III. Display

The unit has a display on the front (see image below). This display shows the status of the unit by means of a green and a red LED and any error messages are displayed (status LED). An overview of possible indications is shown in the table under 7.2 IV. Printed circuit board

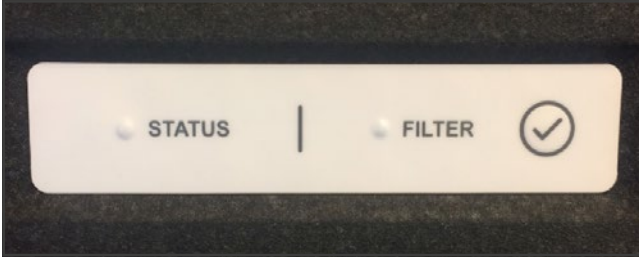

IV. Printed circuit board

The status of the HRC can be read with the red/green LED on the printed circuit board in the HRC. The status can be read off via the flashing pattern of the LED. The following indications are possible:

Overview indications on display/circuit board	
Indication	Message on display/circuit board
Configuration mode active	continuous green
In operation	1x green
Start up unit/RF communication	1x orange
Replace filter	1x green 1x red + Filter LED
Extractor ventilator error	1x red 1x orange
Supply ventilator error	1x red 2x orange
Error both ventilators	1x red 3x orange
Temperature emergency shutdown	2x red 1x orange
Temperature sensor fault x22	2x red 3x orange
Temperature sensor fault x23	2x red 4x orange
Humidity sensor fault	3x red 3x orange
Modbus extractor ventilator fault	4x red 1x orange
Modbus supply ventilator fault	4x red 2x orange
Fault both Modbus ventilators	4x red 3x orange

Set-up mode

In the set-up mode, the green LED will burn continuously for 3 minutes. In set-up mode, it is possible to connect multiple RF components to the unit, see chapter 8 for this.

In operation

After the learning mode, the unit will automatically switch to 'in operation mode'. The unit is working properly.

Replace filter

The 'dirty filter' warning on the display is a tool to clean or replace the filters on time. When the chosen interval time in the printed circuit board has elapsed, it will send a signal to the display on the unit and to the remote control 15RF. After each operation the remote control will now flash 3x orange instead of 1x green. The green LED next to <FILTER> also lights up on the unit display. After cleaning the filters, the warning can be reset by pressing the button next to <FILTER> on the display for 3 seconds. With the 15RF remote control you can reset the filter timer by pressing the <AUTO> and <TIMER> buttons simultaneously.

Extractor ventilator and/or supply ventilator error

This message indicates an error with the supply and/or extractor ventilator. Check if the wiring is properly connected to the printed circuit board: see the diagram on page 15. Check the ventilator for damage and contamination by dismantling it. See Chapter 7.1 for this. If the ventilator is damaged, you must install a new one.

Temperature emergency shutdown

When this message appears on the display, the unit has come to an emergency shutdown. This may indicate that the measured inlet temperature is lower than 5°C. In this case, check how the unit is oriented and connected (left or right). To change the direction of the unit, see Chapter 4.3. Also check whether the bypass valve is closed.

Temperature sensor fault

When a fault occurs with one of the sensors, the display and the printed circuit board indicate which sensor is malfunctioning. See the connection diagram on page 15 for which sensor is connected to which connector. To verify whether the sensor is defective, you can disconnect it from the connector and measure it (10 kΩ at 20°C). If your meter indicates 0 or infinity, the sensor is defective and a new sensor needs to be installed.

To install a new temperature sensor, see how the current sensor is mounted in the unit. Then remove it from the housing and pull it up through the cable entry from the unit, after disconnecting the connector from the printed circuit board. Take the new temperature sensor and feed it through the cable entry with the metal head. Then place the metal head in the appropriate recess: see the illustrations below. Then clamp the rest of the cable into the recess in the housing and attach the connector to the printed circuit board (see Chapter 4.4). Finally, route the cable through the cable ties around the printed circuit board. The fault has now been corrected.

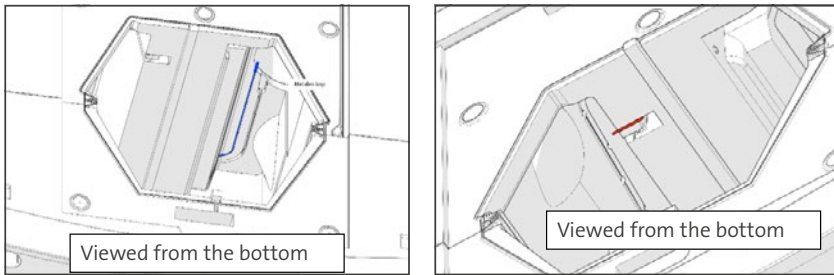

Humidity sensor fault

If the moisture sensor is defective, this is shown on the display. The moisture sensor may not be properly connected to the connector. You can check the operation of the humidity sensor by turning the unit on <AUTO> and breathing over the moisture sensor.

7.3 Ordering new parts

When ordering parts, in addition to the relevant article code number, also specify the unit type, serial number, year of manufacture and the name of the part, for example:

Unit type: HRC-300 EcoMax
Serial Number: 1903570001
Construction year: 2019
Part: Filter set HRC EcoMax
Article number: 22000080

NB.: Unit type and serial number are stated on the identification plate on the bottom of the unit.

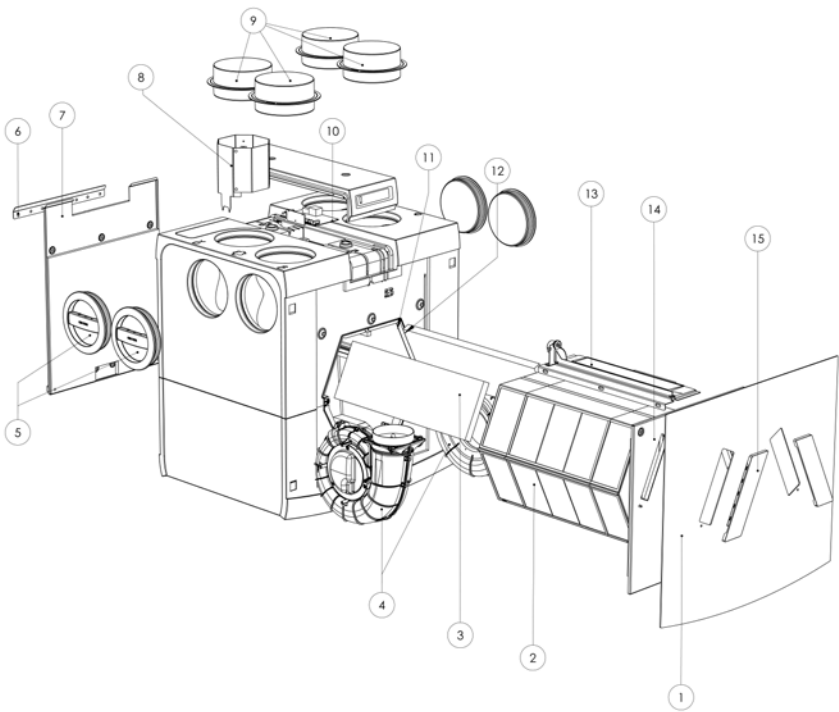

Overview article numbers HRC service articles		
No.	Item Description	Item no.
1	Plastic front panel HRC-EcoMax/MaxComfort	22901330
2	Heat exchanger HRC-EcoMax/MaxComfort	22901303
3a	Filter set HRC-EcoMax (set of 2) Coarse 45%	22700002
3b	Filter set HRC MaxComfort (1x ePM1 70% & 1x Coarse 65% filter)	22700006
3c	Filter set HRC EcoMax (2x Coarse 65% filter)	22700009
3d	Filter Upgrade inlet HRC Ecomax/MaxComfort ePM1 (70%)	22700017
4a	Fan module HRC-300-EcoMax/MaxComfort	22900690
4b	Fan module HRC-400/500-EcoMax/MaxComfort	22900692
5	EPP dop HRC-EcoMax/MaxComfort	22901522
6	Wall bracket HRC-EcoMax/MaxComfort	22900980
8	Preheater (MaxComfort edition)	22900550
9a	Connection flange ϕ 150mm HRC-300-EcoMax/MaxComfort	22910245
9b	Connection flange ϕ 180mm HRC-400-EcoMax/MaxComfort	22910248
10a	Main circuit board HRC-300-EcoMax	22900704
10b	RF antenna HRC-BRPH/EcoMax/ MaxComfort, MVS-15R	22900707
10c	Main circuit board HRC-400-EcoMax	22900715
10d	Main circuit board HRC-300-MaxComfort	22900716
10e	Main circuit board HRC-400-MaxComfort	22900717
10g	Main circuit board HRC-500-EcoMax	22900719
10h	Main circuit board HRC-500-MaxComfort	22900731
10i	LED Display HRC-EcoMax/MaxComfort	22900998
10j	Circuit board EPP cover HRC-EcoMax/MaxComfort	22901520
10k	Perilex cord HRC-EcoMax/MaxComfort	22915405
10l	Earthing cable HRC-EcoMax/MaxComfort	22915426
10m	Ad-on Print Dipswitches HRC-EcoMax/ MaxComfort/ Ventiflow	22900706
11	Circuit board moisture sensor for HRC V2015- present	21915078
11	Temperature sensor HRC-EcoMax/MaxComfort	22901018
13	Bypass module HRC-EcoMax/MaxComfort	22901040
15	Filter grip set left & right HRC-EcoMax/MaxComfort	22900240

8. Technical specifications

8.1 u= HRC-300-EcoMax/MaxComfort

Ventilation setting	Low	Medium	High	Maximum
Ventilation capacity, factory setting [m ³ /h]	100	150	225	300
Power input [W] depends on setting	11	18	40	65
Permissible resistance duct system	200 Pa at 300 m ³ /h			
Dimensions [wxhxd] [mm]	760 x 888 x 592 [height including duct connector pieces]			
Dimensions duct connection [mm]	ø150			
Diameter condensation extractor [mm]	ø32 / G1¼"			
Filter class [ISO16890]	HRC-EcoMax: Coarse 65% HRC-MaxComfort: supply: ePM1 70%, extractor: coarse 65%			
Weight [kg]	34			
Supply voltage [V~/Hz]	230 / 50			
Protection level	IP30			
EPN calculation	Factory setting, medium setting			
Thermal efficiency according to EN-13141-7 [%]	91			

Ventilator graph HRC-300

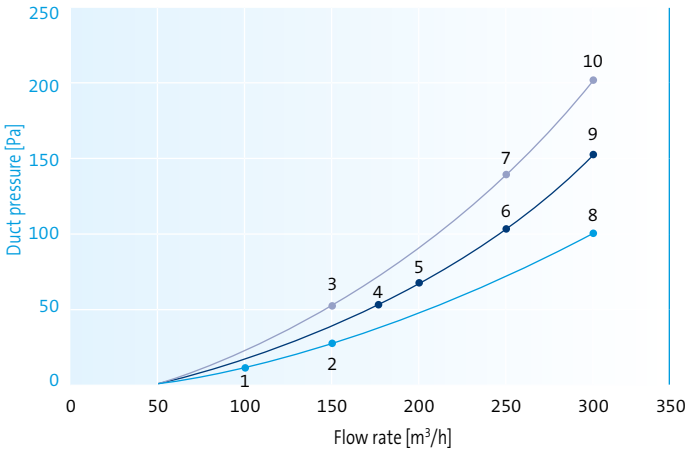

Table associated with HRC-300 ventilator graph

Work point	Reference flow rate [m³/h]	External pressure (Pa)	Power consumption per ventilator (W)	Total power consumption (W)	SPF total (Wh/m³)
1	100	20	4	11	0,11
2	150	25	7	16	0,11
3	150	50	9	20	0,13
4	180	53	11	25	0,14
5	200	65	14	30	0,15
6	250	105	24	51	0,2
7	250	141	28	59	0,24
8	300	100	31	65	0,22
9	300	150	38	79	0,26
10	300	200	46	94	0,31

8.2 HRC-400-EcoMax/MaxComfort

Ventilation setting	Low	Medium	High	Maximum
Ventilation capacity, factory setting [m ³ /h]	100	200	300	400
Power input [W] depends on setting	13	28	60	126
Permissible resistance duct system	200 Pa at 400 m ³ /h			
Dimensions (W x H x D) [m]	760 x 888 x 592 (height including channel connection pieces)			
Dimension of channel connection [mm]	ø180			
Diameter condensate drain [mm]	ø32 / G1¼ "			
Filter class (ISO16890)	HRC-EcoMax: Coarse 65% HRC-MaxComfort: supply: ePM1 70%, drainage: coarse 65%			
Weight [kg]	35			
Supply voltage [V ~ / Hz]	230/50			
Protection level	IP30			
EPN calculation	Factory setting, middle position			
Thermal efficiency according to EN-13141-7 [%]	91			

Ventilator graph HRC-400

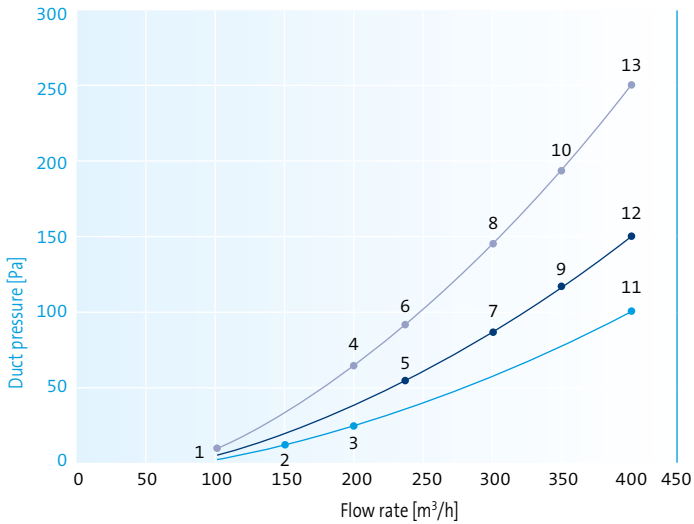

Table corresponding with HRC-400 ventilator graph

Work point	Reference Flow rate (m³/h)	External pressure (Pa)	Power consumption per fan (W)	Total power consumption (W)	SPF total (Wh/m³)
1	100	20	5	13	0,13
2	150	20	7	17	0,11
3	200	25	11	25	0,13
4	200	62,5	15	32	0,16
5	240	53	18	39	0,16
6	240	89	21	44	0,18
7	300	85	29	60	0,20
8	300	140	37	77	0,26
9	350	115	44	90	0,26
10	350	190	55	112	0,32
11	400	100	53	108	0,27
12	400	150	62	126	0,32
13	400	250	79	160	0,40

8.3 Unit data HRC-500-EcoMax/MaxComfort

Ventilation setting	Low	Medium	High	Maximum
Ventilation capacity, factory setting [m ³ /h]	100	220	350	500
Power input [W] depends on setting	13	35	60	185
Permissible resistance duct system	200 Pa at 500 m ³ /h			
Dimensions (W x H x D) [m]	760 x 888 x 592 (height including channel connection pieces)			
Dimension of channel connection [mm]	ø180			
Diameter condensate drain [mm]	ø32 / G1¼"			
Filter class (ISO16890)	HRC-EcoMax: Coarse 65% HRC-MaxComfort: supply: ePM1 70%, drainage: coarse 65%			
Weight [kg]	35			
Supply voltage [V ~ / Hz]	230 / 50			
Protection level	IP30			
EPN calculation	Factory setting, middle position			
Thermal efficiency according to EN-13141-7 [%]	90			

Ventilator graph HRC-500

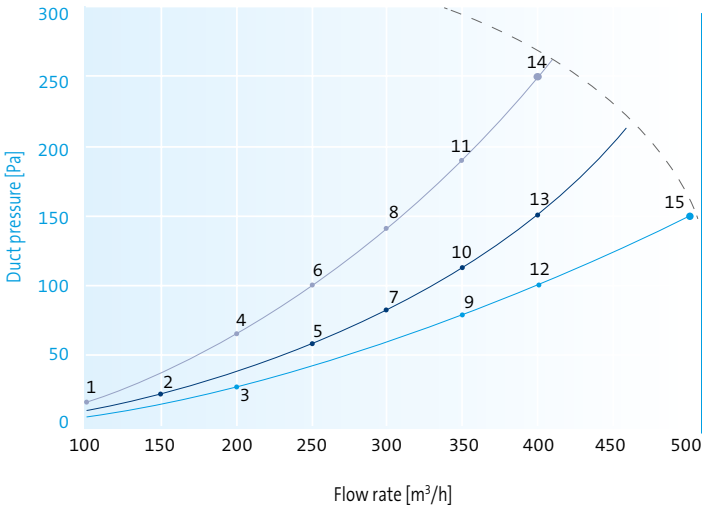

Table corresponding with HRC-500 ventilator graph

Work point	Reference Flow rate (m³/h)	External pressure (Pa)	Power consumption per fan (W)	Total power consumption (W)	SPF total (Wh/m³)
1	100	20	5	13	0,13
2	150	20	7	17	0,11
3	200	25	11	25	0,13
4	200	62,5	15	32	0,16
5	250	60	20	42	0,17
6	250	100	21	50	0,20
7	300	85	29	60	0,20
8	300	140	37	77	0,26
9	350	75	38	79	0,23
10	350	115	44	90	0,26
11	350	190	55	112	0,32
12	400	100	53	108	0,27
13	400	150	62	126	0,32
14	400	250	79	160	0,40
15	500	150	91	185	0,37

8.3 Technical specifications accessories

CO₂ Roomsensor 15RF / CO₂ Controlsensor 15RF	
Power supply	230 Volts
Frequency	50 Hertz
Maximum power consumption	1.2 watts
Temperature class	T40
Dimensions	92 x 92 x 23 mm
Weight	125 grams
RF frequency	868.3 MHz
Min/Max Ambient temperature	0-40°C
RV level	0-90% Non-condensing
Protection class	IP30
Functional measuring range	300 PPM – 2000 PPM
Measurement accuracy	+/- 40 PPM + 5% of measured value

Remote control 15RF	
Power supply	3 Volt battery powered
Temperature class	T40
Dimensions	83 x 80 x 28 mm
Weight	125 grams
RF frequency	868.3 MHz
Min/Max Ambient temperature	0-40°C
RV level	0-90% Non-condensing
Functional measuring range	300 PPM – 2000 PPM
Protection class	IP30

9. Installation report

Date	
Address	
Place	
Project type	
Property type	
Client	
Installed by	
Measured by	
Unit type	
Serial number	

Set flow rate:								
Dip switch no. :	1	2	3	4	5	6	7	8
Extractor [X34]	on/off	on/off	on/off	on/off	on/off	on/off	on/off	on/off
Supply [X35]	on/off	on/off	on/off	on/off	on/off	on/off	on/off	on/off

Settings per room				
Space/valve	Setting on unit	Required [m ³ /h]	Measured [m ³ /h]	MKL valve setting [1-6]
Kitchen				
Toilet				
Bathroom				
Living room				
Bedroom 1				
Bedroom 2				
Bedroom 3				
Other				
Other				

Overview of maintenance services

Date	Activity	Initials

Registered RF components

Other remarks

10. Product fiche

Supplier		Orcon		
Model		HRC-300-EcoMax HRC-300-MaxComfort		
Specific energy consumption	SEC	-82	-43	-18
Climate		Cold	Average	Warm
SEC class		A+	A+	E
Typology		Bidirectional		
Type drive		Multi-speed		
Type heat recovery		Recuperative		
Thermal efficiency	η	91		
Maximum flow rate		300		
Electric power input		132		
Sound power level	L_{wa}	41		
Reference flow rate		0,058		
Reference pressure difference		50		
Specific power input	SPI	0,13		
Control factor and typology		CTRL	MISC	X
		0,85	1,1	2
Leakage		Internal		0,5
		External		1
Mixing rate		-		
Filter warning		On display		
Installation instruction		www.orcon.nl		
Internet adress		www.orcon.nl		
Airflow sensitivity		-		
Air tightness		-		
Annual electricity consumption	AEC	1,3	1,3	1,3
Annual heating saved	AHC	91,0	46,5	21,0
		Cold	Average	Warm

HRC-400-EcoMax HRC-400-MaxComfort			HRC-500-EcoMax HRC-500-MaxComfort				
-81	-42	-17	-80	-41	-16	kWh/[m ² ·A]	
Cold	Average	Warm	Cold	Average	Warm		
A+	A+	E	A+	A	E		
91			89			%	
400			500			m ³ /h	
200			200			W	
47			52			dB[A]	
0,078			0,097			m ³ /s	
50			50			Pa	
0,17			0,19			W/[m ³ /h]	
CTRL	MISC	X	CTRL	MISC	X		
0,85	1,1	2	0,85	1,1	2		
Internal		0,4	Internal		0,5	%	
External		0,8	External		0,6	%	
-			-				
-			-			%	
-			-			m ³ /h	
1,5	1,5	1,5	1,76	1,76	1,76	kWh/[m ² ·A]	
91,0	46,5	21,0	90,30	46,16	20,87	kWh/[m ² ·A]	
Cold	Average	Warm	Cold	Average	Warm		

11. Warranty

Orcon bv grants a standard two-year warranty on the unit. The warranty period starts on the production date.

The warranty will expire if:

- The installation has not been carried out in accordance with the applicable instructions;
- The defects were caused by incorrect connection, improper use or contamination of the ventilators, heat exchanger and accessories;
- Wiring changes have been made;
- Repairs made by third parties.

(Dis) assembly costs on site are not covered by the warranty. If a defect occurs within the warranty period, this must be reported to the installer. Orcon bv reserves the right to change the construction and/or configuration of its products at any time without the obligation to adjust previously delivered products. The information in this manual relates to the most recent information.

12. EC declaration

EG-Verklaring van overeenstemming | Déclaration de conformité CE |
EG-Konformitätserklärung | EC Declaration of Conformity

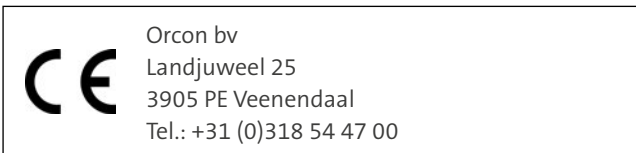

Verklaart dat het product | Déclare que le produit | Erklärt dass das Produkt | Declares that the product:

- HRC-300-EcoMax
- HRC-400-EcoMax
- HRC-500-EcoMax
- HRC-300-MaxComfort
- HRC-400-MaxComfort
- HRC-500-MaxComfort

Voldoet aan de bepalingen gesteld in de richtlijnen | Répond aux exigences des directives | Entspricht den Anforderungen in den Richtlinien | Complies with the requirements stated in the directives:

- Machinery Directive 2006/42/EC
- Low Voltage Directive 2014/35/EU.
- Electromagnetic Compatibility Directive EMC 2014/30/EU.
- Directive establishing a framework for setting ecodesign requirements for energy-related products 2009/125/EC.
- Directive on the indication of energy consumption and consumption of other resources on the labeling and in the standard product information of energy-related products 2010/30/EU.
- Regulation (EU) No. 1253/2014 of the Commission dated 7 July 2014 implementing Directive 2009/125/EC of the European Parliament and the Council with regard to ecodesign requirements for ventilation units.
- Delegated regulation (EU) No. 1254/2014 of the Commission dated 11 July 2014 supplementing Directive 2010/30/EU of the European Parliament and of the Council with regard to energy labeling of residential ventilation units.
- RoHS II directive, 2011/65/EU

Voldoet aan de geharmoniseerde Europese normen | Répond aux normes Européennes harmonisées | Entspricht den harmonisierten europäischen Normen | Complies with the harmonized European standard:

EN 60335-1:2012 EN 55014-1:2007/A1:2009
EN 60335-2 80:2003/A1:2004 EN55014-1:2007/A2:2010
EN 60335-2-80:2003/A2:2009 EN 55014-2:1998
EN 60730-1:2012 EN 55014-2:1998/C1:1998
EN 55014-1:2007 EN 55014-2:1998/A1:2002

Veenendaal, 01-09-2018,



M. Voorhoeve, Managing Director

ORCON

Landjuweel 25, 3905 PE Veenendaal | Postbus 416, 3900 AK Veenendaal
t +31 (0)318 54 47 00 | info@orcon.nl | www.orcon.nl